



# VINIL

**EPOXY-ACRYLATE**



**Option 7**



**Rebar Fixing**



## BCR-400 VINIL

Cartuccia coassiale  
 Coaxial cartridge  
 Cartouche coaxial  
 Koaxialkartusche  
 400 ml  
**cod. 747580**



## BCR-300 VINIL

Cartuccia sacchetto  
 Foil cartridge  
 Cartouche avec sachet  
 Schlauchfolienkartusche  
 300 ml  
**cod. 747568**



## BCR-165 VINIL

Cartuccia sacchetto  
 Foil cartridge  
 Cartouche avec sachet  
 Schlauchfolienkartusche  
 165 ml  
**cod. 747558**



**STOCCAGGIO E CONSERVAZIONE**  
**STORAGE AND CONSERVATION**  
**STOCKAGE ET CONSERVATION**  
**LAGERUNG UND AUFBEWAHRUNG**



**CARTUCCIA**  
**CARTRIDGE**  
**CARTOUCHE**  
**KARTUSCHE**



14

**DURATA (mesi)**  
**EXPIRY (months)**  
**ECHEANGHE (mois)**  
**HALTBARKEIT (Monate)**



16

**DURATA (mesi)**  
**EXPIRY (months)**  
**ECHEANGHE (mois)**  
**HALTBARKEIT (Monate)**

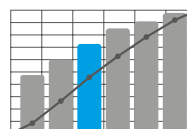



**SCHEDA TECNICA  
TECHNICAL DATA SHEET  
FICHE TECHNIQUE  
TECHNISCHES DATENBLATT**



**EPOXY-ACRYLATE**

**GREEN LIFE**



**VINIL**

RESINA EPOSSIACRILATO SENZA STIRENE | EPOXY ACRYLATE RESIN STYRENE FREE  
RÉSINE EPOXY ACRYLATE SANS STYRÈNE | EPOXYACRYLAT-HARZ STYROLFREI

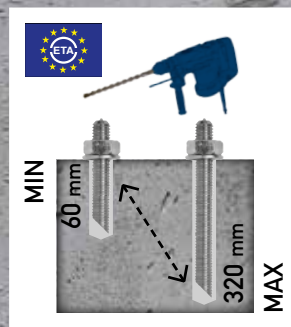
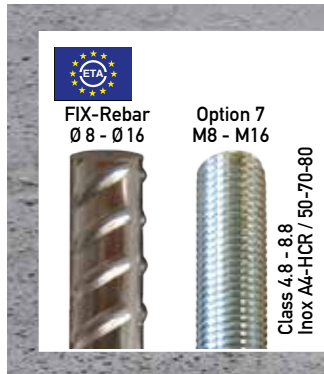

**IT. ANCORANTE CHIMICO BI-COMPONENTE EPOSSIACRILATO SENZA STIRENE PER CARICHI MEDIO/PESANTI, MARCATO CE E QUALIFICATO ETA PER FISSAGGI IN CALCESTRUZZO.**

ETA (European Technical Assessment) aggiornati in accordo al Regolamento Prodotti da Costruzione 305/2011.

ETA-15/0708: Qualifica per calcestruzzo non fessurato, Opzione 7, in accordo a EAD 330499-01-0601, diametri da M8 a M16 e barre ad aderenza migliorata da Ø8 mm a Ø16 mm. Il prodotto è omologato per fissaggi con profondità variabile di ancoraggio, per dare al progettista un'elevata flessibilità. Incremento della massima profondità di ancoraggio fino a venti volte il diametro nominale della barra filettata. Possibilità di utilizzo del prodotto in calcestruzzo asciutto, umido. Le temperature di esercizio certificate sono negli intervalli: -40°C/+40°C (T° max lungo periodo = +24°C) e -40°C/+50°C (T° max lungo periodo = +40°C). Adatto anche per fissaggi su muratura piena e forata, legno.

Temperature del supporto (calcestruzzo, muratura ecc...) per l'installazione comprese tra 0°C e +30°C.

Test report relativo al contenuto di VOC e qualifica ECI PLUS relativa alle emissioni di VOC".

**EN. BI-COMPONENT EPOXY-ACRYLATE STYRENE FREE CHEMICAL ANCHOR FOR MEDIUM/HIGH LOADS, CE MARKED AND ETA ASSESSED FOR USE IN CONCRETE.**

ETA (European Technical Assessments) updated according to the Construction Product Regulation 305/2011.

ETA-15/0708: Assessment for uncracked concrete, Option 7, according to EAD 330499-01-0601 for diameters from M8 to M16 and rebar diameters from Ø8 mm to Ø16 mm. It is certified for fixing with variable anchorage depths. This means that the project engineer has with this product a considerable flexibility in the design phase. Rebar. Possibility of using the product in dry and wet concrete. Certified service temperatures are in the ranges: -40°C/+40°C (T° max long period = +24°C) and -40°C/+50°C (T° max long period = +40°C). Suitable also for base material like solid and hollow masonry, wood.

Base material temperature (concrete, bricks, etc...) for installation between 0° and +30°C.

Test report relating to VOC content and ECI PLUS qualification relating to VOC emissions.

**FR. ETA ANCRAGE CHIMIQUE BI-COMPONENT ÉPOXY-ACRYLATE SANS STYRÈNE POUR CHARGES MOYENNES/LOURDES, MARQUAGE CE ET ÉVALUATION ETA POUR ANCRAGE DANS LE BÉTON.**

ETA (Évaluation Technique Européenne) mise à jour conformément au Règlement sur les Produits de Construction 305/2011.

ETA-15/0708 : Évaluation pour béton non fissuré, Option 7, conformément au Guide d'Agrement Technique Européen EAD 330499-01-0601 pour diamètres de M8 à M16 et barres d'armature de diamètres allant de Ø8 mm à Ø16 mm. Le produit est certifié pour un scellement avec des profondeurs d'ancrage variables. Cela signifie que l'ingénieur de projet bénéficie avec ce produit d'une grande flexibilité lors de la phase de design. Barres d'armature. Possibilité d'utilisation du produit dans du béton sec et fluide. Les températures de service certifiées se situent dans l'intervalle suivant : -40°C/+ 40°C (T° max longue période = +24°C) et -40°C/+50°C (T° longue période = +40°C)

Convient également aux matériaux de construction tels que la maçonnerie pleine et creuse, le bois. Température du matériau de construction (béton, briques, etc.) pour une installation entre 0° et + 30°C. Rapport d'essai relatif à la teneur en COV et qualification ECI PLUS relative aux émissions de COV.

**DE. ZWEIKOMPONENTEN EPOXIDACRYLATHARZ, STYROLFREI, CHEMISCHER ANKER FÜR MITTLERE / HOHE BELASTUNGEN, MIT CE-KENNZEICHNUNG VERSEHEN UND FÜR DEN EINSAZT IN BETON GEPRÜFT.**







ETA (European Technical Assessments) gemäß der Bauproduktverordnung 305/2011 aktualisiert.

ETA-15/0708: Bewertung für ungerissenen Beton, Option 7, gemäß EAD 330499-01-0601 für Durchmesser von M8 bis M16 und Bewehrungsdurchmesser von Ø8 mm bis Ø16 mm. Es ist für die Befestigung mit variablen Verankerungstiefen zertifiziert. Dies bedeutet, dass dem Projektgenieur mit diesem Produkt eine hohe Flexibilität in der Entwurfsphase zur Verfügung steht. Bewehrung. Möglichkeit des Einsatzes in trockenem und nassem Beton. Die zertifizierten Betriebstemperaturen liegen in den Bereichen: -40°C/+40°C (Langzeit-T°max = +24°C) und -40°C/+50°C (Langzeit-T°max = +40°C).

Geeignet auch für Grundmaterial wie Voll- und Hohlmauerwerk, Holz. Grundwerkstofftemperatur (Beton, Ziegelsteine usw.) für den Einbau zwischen 0° und + 30°C. Prüfbericht zum VOC-Gehalt und ECI PLUS-Qualifikation bezüglich VOC-Emissionen.



**Gamma prodotti | Product's range | Gamme produits | Warenangebot**

	CODICE > CODE NUMBER	ARTICOLO > ITEM TYPE > ARTIKEL	DESCRIZIONE > DESCRIPTION DESCRIPTION > BESCHREIBUNG	 Nr.
	 <b>747580</b>	<b>BCR 400 VINIL</b>	Cartuccia da > Cartridge of > Cartouche de > Kartusche von 400 ml & Mixer	12
	<b>747568</b>	<b>BCR 300 VINIL</b>	Cartuccia da > Cartridge of > Cartouche de > Kartusche von 300 ml & Mixer	15
	<b>747588</b>	<b>TERMO 165 VINIL</b>	Thermo foil packed Emballage avec feuil thermique > Thermo- Folienverpackung	12
	<b>747599</b>	<b>OSR 400 VINIL SECCHIO</b>	12 x cartucce, 1 x pompa, 24 x mixers 12 x cartridges, 1 x gun, 24 x mixers	1
	<b>747597</b>	<b>OSR 300 VINIL SECCHIO</b>	18 x cartucce, 1 x pompa, 36 x mixers 18 x cartridges, 1 x gun, 36 x mixers	1
	<b>747604</b>	<b>OSR 400 VINIL SECCHIO NP-2M</b>	12 x cartucce, 24 x mixers > 12 x cartridges, 24 x mixers 12 x cartouches, 24 x mixers > 12 x Kartuschen, 24 x Mischer	1
	<b>747602</b>	<b>OSR 300 VINIL SECCHIO NP-2M</b>	18 x cartucce, 36 x mixers > 18 x cartridges, 36 x mixers 18 x cartouches, 36 x mixers > 18 x Kartuschen, 36 x Mischer	1

Secondo mixer > Additional mixer  
Deuxieme mixer > Doppelmischer



CODICE CARTUCCIA > CODE CARTRIDGE  
CODE CARTOUCHE > KARTUSCHE NUMMER  
**000000AX**

**Tempi di posa | Setting times | Temps d'installation | Verlegungszeit**



**VINIL**



	01	02	03
			
30 °C	3 min	20 min	
25 °C	4 min	30 min	
20 °C	6 min	45 min	
10 °C	12 min	1 h 30'	
5 °C	15 min	2 hours	
0 °C	25 min	3 hours	

**+5°C**  
Temperatura minima del prodotto per l'applicazione  
Minimum product temperature for application  
Température minimal de la cartouche pour l'application  
Min Kartouchetemperatur für die Anwendung

**ASCIUTTO | DRY | SEC | TROCKENEM**



CARTUCCIA > CARTRIDGE  
CARTOUCHE > KARTUSCHE  
**300 - 165 ml:**  
Sistema di apertura sacchetto  
Plastic foil opening system  
Système d'ouverture à sachet  
Plastik Folien Öffnungssystem



- 01 Temperatura supporto > Base material temperature > Temperature material de base > Grundmaterial-temperatur
- 02 Tempo di lavorabilità > Open time > Temps de manipulation > Verarbeitungszeit
- 03 Attesa per la messa in carico > Curing time > Temps avant l'application de charge > Bauzeit



**SCHEDA TECNICA  
TECHNICAL DATA SHEET  
FICHE TECHNIQUE  
TECHNISCHES DATENBLATT**

# Nr. FIXINGS

NUMERO FISSAGGI | NUMBER OF FIXINGS  
NOMBRE DE FIXATIONS | ANZAHL DER BEFESTIGUNGEN

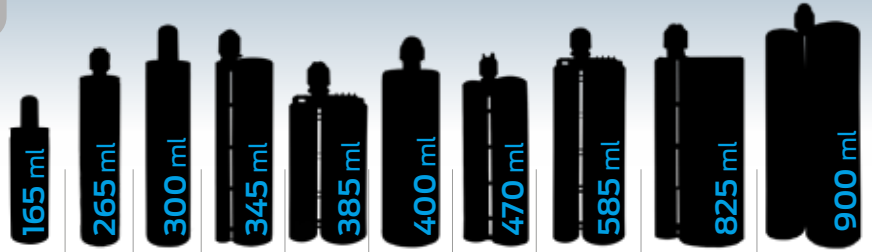

DIAMETRO BARRA ROD DIAMETER DIAMÈTRE DE LA BARRÉ STANGEDURCHMESSER	DIAMETRO FORO HOLE DIAMETER DIAMÈTRE DU TROU BOHRLOCH-DURCHMESSER	PROFONDITÀ EFFETTIVA ANCORAGGIO EFFECTIVE ANCHORAGE DEPTH PROFONDEUR EFFECTIVE D'ANCRAGE EFFEKTIVE VERANKERUNGSTIEFE
---	--	---

	d [mm]	do [mm]	h <sub>eff</sub> [mm]	Numero di fissaggi per cartuccia > Numebr of fixing per cartridge > Nombre de fixations por cartouche > Anzahl der Befestigungen für kartusche									
<b>FISSAGGI NEI MATERIALI PIENI &gt; FIXINGS IN SOLID MATERIALS &gt; FIXATIONS DANS MATERIAUX PLEINS &gt; BEFESTIGUNGEN IN VOLLSTEINEN</b>													
	M8	10	80	± 31,0	± 50,0	± 57,0	± 65,5	± 73,0	± 75,5	± 89,0	± 110,5	± 156,0	± 170,5
	M10	12	90	± 21,5	± 34,0	± 38,5	± 44,5	± 49,5	± 51,5	± 60,5	± 75,5	± 106,5	± 116,0
	M12	14	110	± 14,0	± 22,5	± 25,5	± 29,5	± 33,0	± 34,0	± 40,0	± 50,0	± 70,0	± 76,5
	M14	16	115	± 11,0	± 17,5	± 20,0	± 23,0	± 25,5	± 26,5	± 31,0	± 39,0	± 55,0	± 60,0
	M16	18	125	± 8,5	± 14,0	± 16,0	± 18,5	± 20,5	± 21,0	± 25,0	± 31,0	± 43,5	± 47,5
	M18	20	150	± 6,0	± 9,5	± 11,0	± 12,5	± 14,0	± 14,5	± 17,5	± 21,5	± 30,5	± 33,0
	M20	24	170	± 3,0	± 5,0	± 5,5	± 6,5	± 7,0	± 7,5	± 9,0	± 11,0	± 15,5	± 17,0
	M22	26	190	± 2,5	± 4,0	± 4,5	± 5,5	± 6,0	± 6,0	± 7,0	± 9,0	± 12,5	± 14,0
	M24	28	210	± 2,0	± 3,0	± 3,5	± 4,0	± 4,5	± 5,0	± 5,5	± 7,0	± 10,0	± 11,0
	M27	30	240	± 2,0	± 3,0	± 3,5	± 4,0	± 4,5	± 4,5	± 5,5	± 6,5	± 9,5	± 10,0
	M30	35	270	± 1,0	± 1,5	± 2,0	± 2,0	± 2,5	± 2,5	± 3,0	± 3,5	± 5,0	± 5,5
	M33	37	300	± 1,0	± 1,5	± 2,0	± 2,0	± 2,5	± 2,5	± 3,0	± 3,5	± 5,0	± 5,5
	M36	40	330	± 1,0	± 1,0	± 1,5	± 1,5	± 2,0	± 2,0	± 2,0	± 3,0	± 4,0	± 4,0
M39	42	360	± 1,0	± 1,0	± 1,5	± 1,5	± 2,0	± 2,0	± 2,0	± 2,5	± 4,0	± 4,0	
<b>FISSAGGI NEI MATERIALI PIENI &gt; FIXINGS IN SOLID MATERIALS &gt; FIXATIONS DANS MATERIAUX PLEINS &gt; BEFESTIGUNGEN IN VOLLSTEINEN</b>													
	Ø8	12	80	± 19,5	± 31,0	± 35,0	± 40,5	± 45,0	± 47,0	± 55,0	± 68,5	± 96,5	± 105,5
	Ø10	14	100	± 13,0	± 20,5	± 23,5	± 27,0	± 30,0	± 31,0	± 36,5	± 45,5	± 64,5	± 70,5
	Ø12	16	120	± 9,0	± 14,5	± 16,5	± 19,0	± 21,5	± 22,5	± 26,0	± 32,5	± 46,0	± 50,0
	Ø14	18	140	± 7,0	± 11,0	± 12,5	± 14,5	± 16,0	± 16,5	± 19,5	± 24,5	± 34,5	± 37,5
	Ø16	20	160	± 5,5	± 8,5	± 9,5	± 11,0	± 12,5	± 13,0	± 15,0	± 19,0	± 26,5	± 29,0
	Ø18	22	180	± 4,0	± 7,0	± 7,5	± 9,0	± 10,0	± 10,0	± 12,0	± 15,0	± 21,0	± 23,0
	Ø20	25	200	± 3,0	± 4,5	± 5,0	± 6,0	± 6,5	± 6,5	± 8,0	± 10,0	± 14,0	± 15,0
	Ø22	26	220	± 3,0	± 4,5	± 5,0	± 6,0	± 6,5	± 7,0	± 8,0	± 10,0	± 14,0	± 15,5
	Ø24	28	240	± 2,5	± 4,0	± 4,5	± 5,0	± 5,5	± 6,0	± 7,0	± 8,5	± 12,0	± 13,0
	Ø25	30	250	± 2,0	± 3,0	± 3,0	± 3,5	± 4,0	± 4,5	± 5,0	± 6,5	± 9,0	± 9,5
	Ø26	32	260	± 1,5	± 2,0	± 2,5	± 3,0	± 3,0	± 3,5	± 4,0	± 5,0	± 7,0	± 7,5
	Ø28	35	280	± 1,0	± 1,5	± 2,0	± 2,0	± 2,5	± 2,5	± 3,0	± 3,5	± 5,0	± 5,5
	Ø30	35	300	± 1,0	± 2,0	± 2,5	± 2,5	± 3,0	± 3,0	± 3,5	± 4,5	± 6,0	± 7,0
Ø32	40	320	± 0,5	± 1,0	± 1,5	± 1,5	± 1,5	± 1,5	± 2,0	± 2,5	± 3,5	± 4,0	
<b>FISSAGGI NEI MATERIALI FORATI &gt; FIXINGS IN HOLLOW MATERIALS &gt; FIXATIONS DANS MATERIAUX CREUX &gt; BEFESTIGUNGEN IN LOCHSTEINEN</b>													
	M8	12	50	± 23,5	± 37,5	± 42,5	± 49,0	± 54,5	± 56,5	± 66,5	± 83,0	± 116,5	± 127,5
	M8	12	60	± 19,5	± 31,0	± 35,5	± 40,5	± 45,5	± 47,0	± 55,5	± 69,0	± 97,5	± 106,0
	M8	12	80	± 14,5	± 23,5	± 26,5	± 30,5	± 34,0	± 35,5	± 41,5	± 51,5	± 73,0	± 79,5
	M10	15	85	± 9,0	± 14,0	± 16,0	± 18,5	± 20,5	± 21,5	± 25,0	± 31,0	± 44,0	± 48,0
	M10	15	100	± 7,5	± 12,0	± 13,5	± 15,5	± 17,5	± 18,0	± 21,5	± 26,5	± 37,5	± 40,5
	M10	15	135	± 5,5	± 9,0	± 10,0	± 11,5	± 13,0	± 13,5	± 16,0	± 19,5	± 27,5	± 30,0
	M10	15	140	± 5,5	± 8,5	± 9,5	± 11,0	± 12,5	± 13,0	± 15,0	± 19,0	± 26,5	± 29,0
	M12	20	85	± 5,0	± 8,0	± 9,0	± 10,5	± 11,5	± 12,0	± 14,0	± 17,5	± 24,5	± 27,0
	M14	20	130	± 3,0	± 5,0	± 6,0	± 7,0	± 7,5	± 8,0	± 9,0	± 11,5	± 16,0	± 17,5
	M16	22	150	± 2,5	± 3,5	± 4,0	± 5,0	± 5,5	± 5,5	± 6,5	± 8,0	± 11,5	± 12,5
	M16	22	200	± 1,5	± 3,0	± 3,0	± 3,5	± 4,0	± 4,0	± 5,0	± 6,0	± 8,5	± 9,5
	M20	30	250	± 0,5	± 1,0	± 1,5	± 1,5	± 1,5	± 2,0	± 2,0	± 2,5	± 3,5	± 4,0

> NOTA: Il numero di fissaggi sopra specificato è stato determinato conteggiando esclusivamente il volume teorico di prodotto necessario al riempimento del foro (o gabbietta) escluso il volume della barra inserita. Pur essendo incluso nel calcolo teorico uno spreco standard, il reale quantitativo di prodotto potrà differire da questo in funzione della effettiva modalità di posa in opera adottata.

> WARNING: The number of fixings above mentioned has been calculated according to the theoretical volume needed to fill the hole (or sleeve) excluded the volume of the inserted metal rod. In the theoretical volume it is included a standard extra quantity but the real quantity of the product may be different than it in function of the real application of the product.

> NOTE: Le numéro des fixations sur mentionné a été déterminé en calculant exclusivement le volume théorique de produit nécessaire au remplissage du trou (ou tamis), exclu le volume de la tige filetée. Bien si dans le calcul théorique est incluse une quantité standard de matériel extra, la quantité réelle de produit peut être différente, en fonction des effectives modes d'application du produit.

> ANMERKUNG: Die obengenannte Anzahl der Befestigungen wurde nach dem theoretischen Volumen für die Bohrfüllung (oder Siebhülse-Füllung) minus dem Volumen der Gewindestange berechnet. Im theoretischen Volumen wird eine Standard-Extra-Menge einkalkuliert, aber die wirkliche Produktmenge kann anders sein, abhängig von der wirklichen Anwendung des Produktes.



**Dati installazione | Installation data | Données d'installation | Installationsangaben**

<b>D</b>	Materiale > Material > Matériel > Material
	d [mm] Diametro barra > Rod diameter > Diamètre de la barre > Stangedurchmesser
<b>N</b>	Tipologia di barra > Type of rod > Barre classe > Stange Klasse
	Gabbietta > Plastic sleeve > Tamis > Hülle
<b>E</b>	h <sub>min</sub> [mm] Spessore minimo del supporto > Minimum thickness of base material Épaisseur Minimal du Matière Base > Mindestbauteildicke
	d <sub>0</sub> [mm] Diametro foro > Hole diameter > Diamètre du trou > Bohrlochennendurchmesser
<b>G</b>	h <sub>1</sub> [mm] Profondità del foro > Hole depth > Profondeur du trou > Bohrlochtiefe
	h <sub>nom</sub> [mm] Profondità di inserimento > Embedment depth Profondeur d'enfocé > Setztiefe
<b>L</b>	h <sub>ef</sub> [mm] Profondità effettiva ancoraggio > Effective anchorage depth Profondeur efficace d'ancrage > Effektive Verankerungstiefe

<b>D</b>	S <sub>cr</sub> [mm] Interasse caratteristico > Characteristic spacing Entraxe Caractéristique > Charakteristische Achsabstand
	C <sub>cr</sub> [mm] Distanza dal bordo caratteristica > Characteristic edge distance Distance du bord caractéristique > Charakteristische Randabstand
<b>N</b>	S <sub>min</sub> [mm] Interasse minimo > Minimum allowable spacing Entraxe minimale > Minimaler Achsabstand
	C <sub>min</sub> [mm] Distanza minima dal bordo > Minimum allowable edge distance Distance du bord minimale > Minimaler Randabstand
<b>E</b>	t <sub>fix</sub> [mm] Spessore fissabile > Fixture thickness Épaisseur fixable > Anbauteildicke
	d <sub>f</sub> [mm] Diametro foro spessore fissabile > Diameter of clearance hole in the fixture Diamètre du trou de épaisseur fixable > Durchgangsloch im Anbauteil
<b>G</b>	S <sub>w</sub> [mm] Chiave > Key > Clef > Schlüsselweite
	T <sub>inst</sub> [Nm] Coppia di serraggio > Installation torque Couple de serrage > Drehmoment Beim Verankern

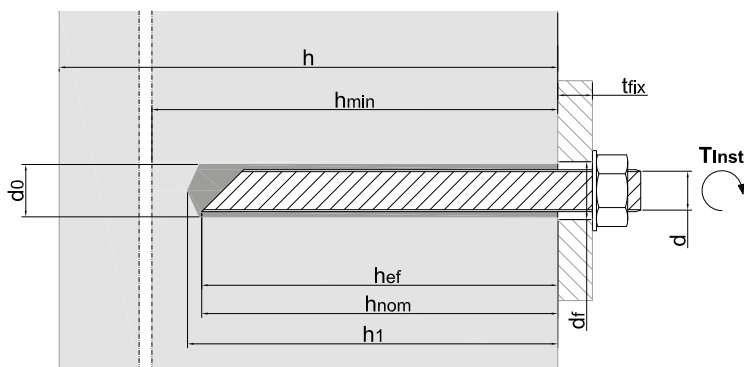

- > **NOTA:** Prima dell'installazione del prodotto consultare la presente sezione e la procedura di installazione completa riportata nelle pagine successive. Si declina ogni responsabilità per l'uso improprio del prodotto.
- > **WARNING:** Before use see this section and the complete procedure of installation reported in the next pages. We assume no liability for the not correct use of the product.
- > **NOTE:** avant l'installation du produit nous vous prions de lire cette section et la procédure d'installation complète que Vous trouvez dans les pages suivantes. Nous n'assumons pas de responsabilité pour une utilisation incorrecte du produit.
- > **ANMERKUNG:** vor der Installation des Produktes bitte diesen Abschnitt und das komplette Installationsverfahren in den folgenden Seiten lesen. Wir übernehmen keine Haftung für die inkorrekte Anwendung des Produktes.



Opzione > Option 7  
M8 ... M16



MATERIALE MATERIAL	DIAMETRO BARRA ROD DIAMETER	TIPOLOGIA DI BARRA TYPE OF ROD	SPESSORE MIN. DEL SUPPORTO MIN. THICKNESS BASE MATERIAL			DIAMETRO FORO HOLE DIAMETER	PROFONDITÀ DEL FORO HOLE DEPTH			PROFONDITÀ DI INSERIMENTO EMBEDMENT DEPTH			PROFONDITÀ EFF. ANCORAGGIO EFFECTIVE ANCHORAGE DEPTH			INTERASSE CARATTERISTICO CHARACTERISTIC SPACING			DISTANZA DAL BORDO CARATTERISTICA CHARACTERISTIC EDGE DISTANCE		
			min	med	max		min	med	max	min	med	max	min	med	max	min	med	max	min	med	max
 <b>M8-M16</b> Calcestruzzo non fessurato Non cracked Concrete	M8	≥ 5.8 A4-70	100	110	190	10	65	85	165	60	80	160	60	80	160	180	211	211	90	105	105
	M10	≥ 5.8 A4-70	100	120	230	12	75	95	205	70	90	200	70	90	200	210	263	263	105	132	132
	M12	≥ 5.8 A4-70	110	140	270	14	85	115	245	80	110	240	80	110	240	240	291	291	120	145	145
	M16	≥ 5.8 A4-70	136	161	356	18	105	130	325	100	125	320	100	125	320	300	360	360	150	180	180



# SCHEDA TECNICA TECHNICAL DATA SHEET FICHE TECHNIQUE TECHNISCHES DATENBLATT



Opzione > Option 7



M8 ... M16

MATERIALE MATERIAL	DIAMETRO BARRA ROD DIAMETER	TIPOLOGIA DI BARRA TYPE OF ROD	INTERASSE MIN. ALLOWABLE SPACING	DISTANZA MIN. DAL BORDO MIN. ALLOWABLE EDGE DISTANCE	DIAMETRO FORO SPESS. FISSABILE DIAMETER OF CLEARANCE HOLE IN THE FIXTURE	CHIAVE KEY	COPIA DI SERRAGGIO INSTALLATION TORQUE
	d [mm]		S <sub>min</sub> [mm]	C <sub>min</sub> [mm]	d <sub>r</sub> [mm]	S <sub>w</sub> [mm]	T <sub>inst</sub> [Nm]
 M8-M16 Calcestruzzo non fessurato Non cracked Concrete  	M8	≥ 5.8 A4-70	40	40	9	13	10
	M10	≥ 5.8 A4-70	50	40	12	17	20
	M12	≥ 5.8 A4-70	60	40	14	19	40
	M16	≥ 5.8 A4-70	75	50	18	24	80

- > Per evitare una possibile rottura per splitting, lo spessore del supporto in calcestruzzo dovrà essere  $h \geq 2h_{ef}$
- > To avoid splitting failure, the thickness of the concrete member shall be  $h \geq 2h_{ef}$
- > Pour éviter une possible rupture par splitting, l'épaisseur du support en béton devrait être  $h \geq 2h_{ef}$
- > Um einen splittingbedingten Bruch zu verhindern, die Dicke der Unterlage aus Beton muss  $h \geq 2h_{ef}$  sein



Opzione > Option 7





M8 ... M16



MATERIALE MATERIAL	DIAMETRO BARRA ROD DIAMETER	TIPOLOGIA DI BARRA TYPE OF ROD	SPESSORE MIN. DEL SUPPORTO MIN. THICKNESS BASE MATERIAL			DIAMETRO FORO HOLE DIAMETER	PROFONDITÀ DEL FORO HOLE DEPTH			PROFONDITÀ EFF. ANCORAGGIO EFFECTIVE ANCHORAGE DEPTH			INTERASSE CARATTERISTICO CHARACTERISTIC SPACING			DISTANZA DAL BORDO CARATTERISTICA CHARACTERISTIC EDGE DISTANCE			INTERASSE MIN. ALLOWABLE SPACING	DISTANZA MIN. DAL BORDO MIN. ALLOWABLE EDGE DISTANCE
	d [mm]		h <sub>min</sub> [mm]			d <sub>0</sub> [mm]	h <sub>1</sub> [mm]			h <sub>ef</sub> [mm]			S <sub>cr,N</sub> [mm]			C <sub>cr,N</sub> [mm]			S <sub>min</sub> [mm]	C <sub>min</sub> [mm]
			min	med	max		min	med	max	min	med	max	min	med	max	min	med	max		
 Ø8-Ø16 Calcestruzzo non fessurato Non cracked Concrete  	Ø 8	B450C BST500	100	110	190	12	65	85	165	60	80	160	180	202	202	90	101	101	50	40
	Ø 10	B450C BST500	100	120	230	14	75	95	205	70	90	200	210	242	242	105	121	121	60	40
	Ø 12	B450C BST500	112	142	272	16	85	115	245	80	110	240	240	277	277	120	139	139	65	40
	Ø 14	B450C BST500	116	161	316	18	85	130	285	80	125	280	240	323	323	120	162	162	75	40
	Ø 16	B450C BST500	140	180	360	20	105	145	325	100	125	320	300	351	351	150	175	175	80	50





MATERIALE MATERIAL	DIAMETRO BARRA ROD DIAMETER	TIPOLOGIA DI BARRA TYPE OF ROD	SPESORE MIN. DEL SUPPORTO MIN. THICKNESS BASE MATERIAL	DIAMETRO FORO HOLE DIAMETER	PROFONDITÀ DEL FORO HOLE DEPTH	PROFONDITÀ DI INSERIMENTO EMBEDMENT DEPTH	PROFONDITÀ EFF. ANCORAGGIO EFFECTIVE ANCHORAGE DEPTH	INTERASSE CARATTERISTICO CHARACTERISTIC SPACING	DISTANZA DAL BORDO CARATTERISTICA CHARACTERISTIC EDGE DISTANCE	INTERASSE MIN. ALLOWABLE SPACING	DISTANZA MIN. DAL BORDO MIN. ALLOWABLE EDGE DISTANCE	SPESS. FISSABILE MAX FIXTURE THICKNESS	DIAMETRO FORO SPRESS. FISSABILE DIAMETER OF CLEARANCE HOLE IN THE FIXTURE	CHIAVE KEY	COPIA DI SERRAGGIO INSTALLATION TORQUE
	d [mm]		h <sub>min</sub> [mm]	d <sub>0</sub> [mm]	h <sub>1</sub> [mm]	h <sub>nom</sub> [mm]	h <sub>eff</sub> [mm]	S <sub>cr</sub> [mm]	C <sub>cr</sub> [mm]	S <sub>min</sub> [mm]	C <sub>min</sub> [mm]	t <sub>fix</sub> [mm]	d <sub>f</sub> [mm]	S <sub>w</sub> [mm]	T <sub>inst</sub> [Nm]
 Mattone pieno Solid Brick Brique pleine Vollmauerwerk	M8	≥ 4.6 A2-70 A4-70	200	10	85	80	80	160	200	100	100	10	9	13	7
	M10	≥ 4.6 A2-70 A4-70	250	12	90	85	85	200	200	100	100	20	12	17	15
	M12	≥ 4.6 A2-70 A4-70	300	14	100	95	95	240	200	100	100	30	14	19	25
	M16	≥ 4.6 A2-70 A4-70	350	18	130	125	125	320	200	100	100	35	18	24	30

MATERIALE MATERIAL	DIAMETRO BARRA ROD DIAMETER	TIPOLOGIA DI BARRA TYPE OF ROD	GABBETTA PLASTIC SLEEVE	SPESORE MIN. DEL SUPPORTO MIN. THICKNESS BASE MATERIAL	DIAMETRO FORO HOLE DIAMETER	PROFONDITÀ DEL FORO HOLE DEPTH	PROFONDITÀ DI INSERIMENTO EMBEDMENT DEPTH	PROFONDITÀ EFF. ANCORAGGIO EFFECTIVE ANCHORAGE DEPTH	INTERASSE CARATTERISTICO CHARACTERISTIC SPACING	DISTANZA DAL BORDO CARATTERISTICA CHARACTERISTIC EDGE DISTANCE	INTERASSE MIN. ALLOWABLE SPACING	DISTANZA MIN. DAL BORDO MIN. ALLOWABLE EDGE DISTANCE	SPESS. FISSABILE MAX FIXTURE THICKNESS	DIAMETRO FORO SPRESS. FISSABILE DIAMETER OF CLEARANCE HOLE IN THE FIXTURE	CHIAVE KEY	COPIA DI SERRAGGIO INSTALLATION TORQUE
	d [mm]		(*)	h <sub>min</sub> [mm]	d <sub>0</sub> [mm]	h <sub>1</sub> [mm]	h <sub>nom</sub> [mm]	h <sub>eff</sub> [mm]	S <sub>cr</sub> [mm]	C <sub>cr</sub> [mm]	S <sub>min</sub> [mm]	C <sub>min</sub> [mm]	t <sub>fix</sub> [mm]	d <sub>f</sub> [mm]	S <sub>w</sub> [mm]	T <sub>inst</sub> [Nm]
 Mattone forato Hollow Brick Brique creux Lochziegel	M8	≥ 4.6 A2-70 A4-70	GC 12x80	100	12	85	80	80	l <sub>unit,max</sub>	0,5 x l <sub>unit,max</sub>	100	100	10	9	13	3
	M10	≥ 4.6 A2-70 A4-70	GC 15x85	100	16	90	85	85	l <sub>unit,max</sub>	0,5 x l <sub>unit,max</sub>	100	100	20	12	17	4
	M12	≥ 4.6 A2-70 A4-70	GC 20x85	100	20	90	85	85	l <sub>unit,max</sub>	0,5 x l <sub>unit,max</sub>	120	120	30	14	19	6

(\*) Altre lunghezze disponibili, vedi catalogo > Other lengths available see catalogue

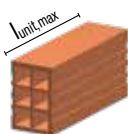
l<sub>unit,max</sub> = Massima dimensione del blocco di muratura > Max length of masonry unit  
 Dimension maximale du bloc de maçonnerie > Maximale Größe des Ziegelsteins



MATERIALE MATERIAL	DIAMETRO BARRA ROD DIAMETER	TIPOLOGIA DI BARRA TYPE OF ROD	SPESORE MIN. DEL SUPPORTO MIN. THICKNESS BASE MATERIAL	DIAMETRO FORO HOLE DIAMETER	PROFONDITÀ DEL FORO HOLE DEPTH	PROFONDITÀ DI INSERIMENTO EMBEDMENT DEPTH	PROFONDITÀ EFF. ANCORAGGIO EFFECTIVE ANCHORAGE DEPTH	INTERASSE CARATTERISTICO CHARACTERISTIC SPACING	DISTANZA DAL BORDO CARATTERISTICA CHARACTERISTIC EDGE DISTANCE	INTERASSE MIN. ALLOWABLE SPACING	DISTANZA MIN. DAL BORDO MIN. ALLOWABLE EDGE DISTANCE	SPESS. FISSABILE MAX FIXTURE THICKNESS	DIAMETRO FORO SPRESS. FISSABILE DIAMETER OF CLEARANCE HOLE IN THE FIXTURE	CHIAVE KEY	COPIA DI SERRAGGIO INSTALLATION TORQUE
	d [mm]		h <sub>min</sub> [mm]	d <sub>0</sub> [mm]	h <sub>1</sub> [mm]	h <sub>nom</sub> [mm]	h <sub>eff</sub> [mm]	S <sub>cr</sub> [mm]	C <sub>cr</sub> [mm]	S <sub>min</sub> [mm]	C <sub>min</sub> [mm]	t <sub>fix</sub> [mm]	d <sub>f</sub> [mm]	S <sub>w</sub> [mm]	T <sub>inst</sub> [Nm]
 Legno lamellare Laminated Timber Holz	M8	≥ 4.6 A2-70 A4-70	160	10	85	80	80	100	80	50	50	10	9	13	7
	M10	≥ 4.6 A2-70 A4-70	200	12	105	100	100	125	100	50	50	20	12	17	15
	M12	≥ 4.6 A2-70 A4-70	240	14	125	120	120	150	120	60	60	30	14	19	25
	M16	≥ 4.6 A2-70 A4-70	320	18	165	160	160	200	160	80	80	35	18	24	30



# SCHEDA TECNICA TECHNICAL DATA SHEET FICHE TECHNIQUE TECHNISCHES DATENBLATT

## Dati carico | Load data | Données de charge | Lastdaten





<b>D</b>	$N_{rk}$ [kN]	Carico caratteristico a trazione > Characteristic tension load > Charge caractéristique de traction Charakteristische Zuglast
	$V_{rk}$ [kN]	Carico caratteristico a taglio > Characteristic shear load > Charge caractéristique de cisaillement Charakteristische Querlast
<b>E</b>	$N_{rd}$ [kN]	Carico di progetto di trazione > Design tensile load Projektlast Zuglast > Charge de calcul de traction
	$V_{rd}$ [kN]	Carico di progetto di taglio > Design shear load Projektlast Querlast > Charge de calcul de cisaillement
<b>L</b>	$N_{rec}$ [kN]	Carico ammissibile a trazione > Admissible tensile load > Charge admissible de traction > Zulässige Zuglast
	$V_{rec}$ [kN]	Carico ammissibile a taglio > Admissible shear load > Charge admissible de cisaillement > Zulässige Querlast

- > Carichi validi per singolo ancorante senza influenza di interasse e distanza dal bordo e  $h \geq 2h_{ef}$  >  $1kN = 100 Kg$
- > Loads for single anchor with no influence of spacing and edge distance and with  $h \geq 2h_{ef}$  >  $\psi_{sa} = 1,0$
- > Charges valables pour chaque ancrage sans influence d'interaxe et distance du bord et  $h \geq 2h_{ef}$
- > Passende Ringe für den einzelnen Veranker, ohne Achsenabstandseinfluss und des Randabstands und  $h \geq 2h_{ef}$

- > Azione di taglio non diretta verso il bordo > Coefficiente di sicurezza globale incluso > Coefficiente lato carichi utilizzato = 1,4
- > Shear directed away from the edge > General safety factor included > Load increasing safety coefficient used = 1,4
- > Action de cisaillement pas dirigée vers le bord > Coefficient de sécurité générale inclu > Coefficient côté charge utilisé = 1,4
- > Queraktion nicht an den Rand gerichtet > Generelle Sicherheitskoeffizient inbegriffen > Verwendeter Lasterhöhungssicherheitskoeffizient = 1,4

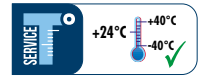
## MIN Dati di carico con profondità effettiva ancoraggio MINIMA > Load data with MINIMUM effective anchorage depth Donnes de charge avec profondeur efficace d'ancrage MINIMALE > Lastdaten mit MINIMALER effektiven Verankerungstiefe



VINIL MATERIALE MATERIAL	BARRA ROD	DIAMETRO BARRA ROD DIAMETER	PROFONDITÀ EFF. ANCORAGGIO EFFECTIVE ANCHORAGE DEPTH	CARICO CARATTERISTICO A TRAZIONE CHARACTERISTIC TENSILE LOAD	CARICO CARATTERISTICO A TAGLIO CHARACTERISTIC SHEAR LOAD	CARICO DI PROGETTO DI TRAZIONE DESIGN TENSILE LOAD	CARICO DI PROGETTO DI TAGLIO DESIGN SHEAR LOAD	CARICO AMMISSIBILE A TRAZIONE ADMISSIBLE TENSILE LOAD	CARICO AMMISSIBILE A TAGLIO ADMISSIBLE SHEAR LOAD
				$N_{rk}$ [kN]	$V_{rk}$ [kN]	$N_{rd}$ [kN]	$V_{rd}$ [kN]	$N_{rec}$ [kN]	$V_{rec}$ [kN]
C20/25 Calcestruzzo non fessurato Non cracked Concrete Beton non fissuré Ungerissener Beton  $\geq 5.8$	$\geq 5.8$	M 8	60	19,0	9,5	10,9	7,6	7,8	5,4
	$\geq 5.8$	M 10	70	28,6	15,1	15,9	12,1	11,3	8,6
	$\geq 5.8$	M 12	80	33,2	21,9	18,4	17,5	13,2	12,5
	$\geq 5.8$	M 16	100	47,8	40,8	26,5	32,6	18,9	23,3

## MED Dati di carico con profondità effettiva ancoraggio MEDIA > Load data with MEDIUM effective anchorage depth Donnes de charge avec profondeur efficace d'ancrage MOYENNE > Lastdaten mit MITTLERER effektiven Verankerungstiefe



VINIL MATERIALE MATERIAL	BARRA ROD	DIAMETRO BARRA ROD DIAMETER	PROFONDITÀ EFF. ANCORAGGIO EFFECTIVE ANCHORAGE DEPTH	CARICO CARATTERISTICO A TRAZIONE CHARACTERISTIC TENSILE LOAD	CARICO CARATTERISTICO A TAGLIO CHARACTERISTIC SHEAR LOAD	CARICO DI PROGETTO DI TRAZIONE DESIGN TENSILE LOAD	CARICO DI PROGETTO DI TAGLIO DESIGN SHEAR LOAD	CARICO AMMISSIBILE A TRAZIONE ADMISSIBLE TENSILE LOAD	CARICO AMMISSIBILE A TAGLIO ADMISSIBLE SHEAR LOAD
				$N_{rk}$ [kN]	$V_{rk}$ [kN]	$N_{rd}$ [kN]	$V_{rd}$ [kN]	$N_{rec}$ [kN]	$V_{rec}$ [kN]
C20/25 Calcestruzzo non fessurato Non cracked Concrete Beton non fissuré Ungerissener Beton  $\geq 5.8$	$\geq 5.8$	M 8	80	19,0	9,5	12,7	7,6	9,0	5,4
	$\geq 5.8$	M 10	90	30,2	15,1	20,1	12,1	14,4	8,6
	$\geq 5.8$	M 12	110	43,8	21,9	25,3	17,5	18,1	12,5
	$\geq 5.8$	M 16	125	59,7	40,8	33,2	32,6	23,7	23,3

## MAX Dati di carico con profondità effettiva ancoraggio MASSIMO > Load data with MAXIMUM effective anchorage depth Donnes de charge avec profondeur efficace d'ancrage MAXIMUM > Lastdaten mit MAXIMALER effektiven Verankerungstiefe



VINIL MATERIALE MATERIAL	BARRA ROD	DIAMETRO BARRA ROD DIAMETER	PROFONDITÀ EFF. ANCORAGGIO EFFECTIVE ANCHORAGE DEPTH	CARICO CARATTERISTICO A TRAZIONE CHARACTERISTIC TENSILE LOAD	CARICO CARATTERISTICO A TAGLIO CHARACTERISTIC SHEAR LOAD	CARICO DI PROGETTO DI TRAZIONE DESIGN TENSILE LOAD	CARICO DI PROGETTO DI TAGLIO DESIGN SHEAR LOAD	CARICO AMMISSIBILE A TRAZIONE ADMISSIBLE TENSILE LOAD	CARICO AMMISSIBILE A TAGLIO ADMISSIBLE SHEAR LOAD
				$N_{rk}$ [kN]	$V_{rk}$ [kN]	$N_{rd}$ [kN]	$V_{rd}$ [kN]	$N_{rec}$ [kN]	$V_{rec}$ [kN]
C20/25 Calcestruzzo non fessurato Non cracked Concrete Beton non fissuré Ungerissener Beton  $8.8$	8.8	M 8	160	29,2	14,6	19,5	11,7	13,9	8,3
	8.8	M 10	200	46,4	23,2	30,9	18,6	22,1	13,3
	8.8	M 12	240	67,4	33,7	44,9	27,0	32,1	19,3
	8.8	M 16	320	125,0	62,5	83,3	50,0	59,5	35,7





**Dati carico | Load data | Données de charge | Lastdaten**

<b>D N E G L</b>	<b>N<sub>rk</sub> [kN]</b>	Carico caratteristico a trazione > Characteristic tension load > Charge caractéristique de traction Charakteristische Zuglast
	<b>V<sub>rk</sub> [kN]</b>	Carico caratteristico a taglio > Characteristic shear load > Charge caractéristique de cisaillement Charakteristische Querlast
	<b>N<sub>rd</sub> [kN]</b>	Carico di progetto di trazione > Design tensile load Projektlast Zuglast > Charge de calcul de traction
	<b>V<sub>rd</sub> [kN]</b>	Carico di progetto di taglio > Design shear load Projektlast Querlast > Charge de calcul de cisaillement
	<b>N<sub>rec</sub> [kN]</b>	Carico ammissibile a trazione > Admissible tensile load > Charge admissible de traction > Zulässige Zuglast
	<b>V<sub>rec</sub> [kN]</b>	Carico ammissibile a taglio > Admissible shear load > Charge admissible de cisaillement > Zulässige Querlast



- > Applicazioni in accordo alla teoria dell'ancoraggio
- > Application according to the anchors theory
- > Application en conformité avec la théorie de l'ancrage
- > Anwendung in Übereinstimmung mit der Verankerungstheorie

- > Carichi validi per singolo ancorante senza influenza di interasse e distanza dal bordo e  $h \geq 2h_f$
- > Loads for single anchor with no influence of spacing and edge distance and with  $h \geq 2h_f$
- > Charges valables pour chaque ancrage sans influence d'interaxe et distance du bord et  $h \geq 2h_f$
- > Passende Ringe für den einzelnen Veranker, ohne Achsenabstandseinfluss und des Randabstands und  $h \geq 2h_f$

- > Azione di taglio non diretta verso il bordo
- > Shear directed away from the edge
- > Action de cisaillement pas dirigée vers le bord
- > Queraktion nicht an den Rand gerichtet
- > Coefficiente di sicurezza globale incluso
- > General safety factor included
- > Coefficient de sécurité générale inclu
- > Generelle Sicherheitskoeffizient inbegriffen
- > Coefficiente lato carichi utilizzato = 1,4
- > Load increasing safety coefficient used = 1,4
- > Coefficient côté charge utilisé = 1,4
- > Verwendeter Lasterhöhungssicherheitskoeffizient = 1,4

**MIN** Dati di carico con profondità effettiva ancoraggio MINIMA > Load data with MINIMUM effective anchorage depth  
Donnes de charge avec profondeur efficace d'ancrage MINIMALE > Lastdaten mit MINIMALER effektiven Verankerungstiefe



VINIL	MATERIALE MATERIAL	DIAMETRO BARRA ROD DIAMETER	PROFONDITÀ EFF. ANCORAGGIO EFFECTIVE ANCHORAGE DEPTH		CARICO CARATTERISTICO A TRAZIONE CHARACTERISTIC TENSILE LOAD	CARICO CARATTERISTICO A TAGLIO CHARACTERISTIC SHEAR LOAD	CARICO DI PROGETTO DI TRAZIONE DESIGN TENSILE LOAD	CARICO DI PROGETTO DI TAGLIO DESIGN SHEAR LOAD	CARICO AMMISSIBILE A TRAZIONE ADMISSIBLE TENSILE LOAD	CARICO AMMISSIBILE A TAGLIO ADMISSIBLE SHEAR LOAD
			d [mm]	$h_{ef MIN}$ [mm]						
C20/25 Calcestruzzo non fessurato Non cracked Concrete Beton non fissuré Ungerissener Beton	Rebar B450C BST500	Ø 8	60	18,1	13,6	12,1	9,0	8,6	6,5	
		Ø 10	70	24,2	21,2	16,1	14,1	11,5	10,1	
		Ø 12	80	30,2	30,5	20,1	20,4	14,4	14,5	
		Ø 14	80	35,2	41,6	23,5	27,7	16,8	19,8	
		Ø 16	100	45,2	54,3	30,2	36,2	21,5	25,9	

**MED** Dati di carico con profondità effettiva ancoraggio MEDIA > Load data with MEDIUM effective anchorage depth  
Donnes de charge avec profondeur efficace d'ancrage MOYENNE > Lastdaten mit MITTLERER effektiven Verankerungstiefe



VINIL	MATERIALE MATERIAL	DIAMETRO BARRA ROD DIAMETER	PROFONDITÀ EFF. ANCORAGGIO EFFECTIVE ANCHORAGE DEPTH		CARICO CARATTERISTICO A TRAZIONE CHARACTERISTIC TENSILE LOAD	CARICO CARATTERISTICO A TAGLIO CHARACTERISTIC SHEAR LOAD	CARICO DI PROGETTO DI TRAZIONE DESIGN TENSILE LOAD	CARICO DI PROGETTO DI TAGLIO DESIGN SHEAR LOAD	CARICO AMMISSIBILE A TRAZIONE ADMISSIBLE TENSILE LOAD	CARICO AMMISSIBILE A TAGLIO ADMISSIBLE SHEAR LOAD
			d [mm]	$h_{ef MED}$ [mm]						
C20/25 Calcestruzzo non fessurato Non cracked Concrete Beton non fissuré Ungerissener Beton	Rebar B450C BST500	Ø 8	80	24,1	13,6	16,1	9,0	11,5	6,5	
		Ø 10	90	31,1	21,2	20,7	14,1	14,8	10,1	
		Ø 12	110	41,5	30,5	27,6	20,4	19,7	14,5	
		Ø 14	125	55,0	41,6	36,7	27,7	26,2	19,8	
		Ø 16	140	63,3	54,3	42,2	36,2	30,2	25,9	





**MAX** Dati di carico con profondità effettiva ancoraggio MASSIMO > Load data with MAXIMUM effective anchorage depth  
Donnes de charge avec profondeur efficace d'ancrage MAXIMUM > Lastdaten mit MAXIMALER effektiven Verankerungstiefe



VINIL	MATERIALE MATERIAL	DIAMETRO BARRA ROD DIAMETER	PROFONDITÀ EFF. ANCORAGGIO EFFECTIVE ANCHORAGE DEPTH		CARICO CARATTERISTICO A TRAZIONE CHARACTERISTIC TENSILE LOAD	CARICO CARATTERISTICO A TAGLIO CHARACTERISTIC SHEAR LOAD	CARICO DI PROGETTO DI TRAZIONE DESIGN TENSILE LOAD	CARICO DI PROGETTO DI TAGLIO DESIGN SHEAR LOAD	CARICO AMMISSIBILE A TRAZIONE ADMISSIBLE TENSILE LOAD	CARICO AMMISSIBILE A TAGLIO ADMISSIBLE SHEAR LOAD
			d [mm]	$h_{ef MAX}$ [mm]						
C20/25 Calcestruzzo non fessurato Non cracked Concrete Beton non fissuré Ungerissener Beton	Rebar B450C BST500	Ø 8	160	27,1	13,6	19,4	9,0	13,8	6,5	
		Ø 10	200	42,4	21,2	30,3	14,1	21,6	10,1	
		Ø 12	240	61,1	30,5	43,6	20,4	31,2	14,5	
		Ø 14	280	83,1	41,6	59,4	27,7	42,4	19,8	
		Ø 16	320	108,6	54,3	77,6	36,2	55,4	25,9	



# SCHEDA TECNICA TECHNICAL DATA SHEET FICHE TECHNIQUE TECHNISCHES DATENBLATT

MATERIALE MATERIAL	TIPOLOGIA DI BARRA TYPE OF ROD	DIAMETRO BARRA ROD DIAMETER	CARICO ULTIMO MEDIO A TRAZIONE ULTIMATE TENSION LOAD	CARICO ULTIMO MEDIO A TAGLIO ULTIMATE SHEAR LOAD	CARICO AMMISSIBILE A TRAZIONE ADMISSIBLE TENSILE LOAD	CARICO AMMISSIBILE A TAGLIO ADMISSIBLE SHEAR LOAD
			N <sub>lim</sub> [kN]	V <sub>lim</sub> [kN]	N <sub>rec</sub> [kN]	V <sub>rec</sub> [kN]
<b>YINIL</b> Mattone pieno Solid Brick Brique pleine Vollmauerwerk  <b>≥ 4.6 / A2-70 / A4-70</b>	 ≥ 4.6 A2-70 A4 -70	M8	 > Dati di carico raccomandati per applicazioni su materiali base di medie caratteristiche meccaniche. Vista la varietà dei substrati in muratura e/o legno per applicazioni su supporti differenti da quelli considerati, i valori di carico dovranno essere ricavati tramite opportune prove in situ.  > Recommended loads for applications on base materials with medium strength characteristics. For different masonry and/or wood base materials, load values must be obtained with in situ tests.		2,0	3,0
	≥ 4.6 A2-70 A4 -70	M10		2,6	3,4	
	≥ 4.6 A2-70 A4 -70	M12		2,8	3,9	
	≥ 4.6 A2-70 A4 -70	M16		4,0	4,2	
<b>YINIL</b> Materiale forato Hollow Material Material creuse Lochziegeln  <b>≥ 4.6 / A2-70 / A4-70</b>	 ≥ 4.6 A2-70 A4 -70	M8		0,9	2,0	
	≥ 4.6 A2-70 A4 -70	M10		0,9	2,0	
	≥ 4.6 A2-70 A4 -70	M12		0,9	2,5	
<b>YINIL</b> Legno lamellare Laminated Timber Timber Holz  <b>≥ 4.6 / A2-70 / A4-70</b>	 ≥ 4.6 A2-70 A4 -70	M8		3,2	> Per valori a taglio riferirsi alle istruzioni CNR-DT 206/2007 (7.10.2.3) > For shear loads refer to CNR-DT 206/2007 (7.10.2.3)	
	≥ 4.6 A2-70 A4 -70	M10		4,2		
	≥ 4.6 A2-70 A4 -70	M12		6,1		
	≥ 4.6 A2-70 A4 -70	M16		10,7		



## CHEMICAL ANCHOR FOR CONCRETE, SOLID AND HOLLOW/PERFORATED MASONRY

Ancorante chimico per calcestruzzo, muratura di mattoni pieni e forati > Scellements chimique a injection pour beton, briques pleines et percées > Chemische verankerung für Beton, voll- und lochziegel





# INSTALLATION

PROCEDURA DI INSTALLAZIONE  
INSTALLATION PROCEDURE  
PROCÉDURE D'INSTALLATION  
INSTALLATIONSVERFAHREN

## 01 PULIZIA | CLEANING | NETTOYAGE | REINIGUNG

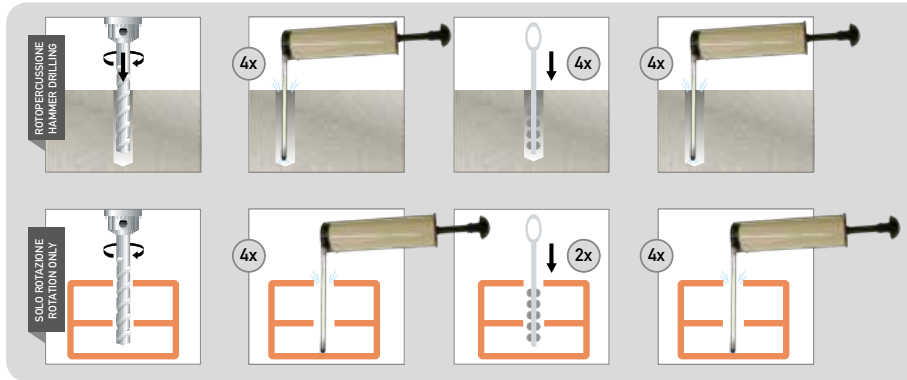

SDS-HDB (pag. 227)

Se utilizzata non necessita di pompa soffiante/aria compressa per la rimozione della polvere dal foro  
If used no need to use blower pump/compressed air to remove the dust from the hole

Eseguire il foro controllandone la perpendicolarità. Soffiare il foro con apposita pompa soffiante (o aria compressa), eseguire operazione di pulizia della superficie laterale del foro con apposito scovolino metallico, soffiare nuovamente il foro fino a che non fuoriesca più polvere e/o altro materiale residuo. Si raccomanda un'attenta pulizia della superficie laterale del foro con scovolino metallico.

Drill the hole and check its perpendicularity. Blow the hole with an appropriate pump blower (or compression air), clean the lateral surface of the hole with an appropriate steel brush, blow again in the hole until there is no dust and/or any residual material inside. We strongly recommend use of the steel brush to clean hole sides.

Réaliser le trou en contrôlant la perpendicularité. Souffler dans le trou avec la pompe soufflante prévue (ou de l'air comprimé), effectuer l'opération de nettoyage de la surface latérale du trou avec un écouvillon métallique, souffler à nouveau dans le trou jusqu'à ce qu'il n'en sorte plus de poussière et/ou d'autres matières résiduelles. Nous recommandons l'utilisation d'écouvillon métallique pour le nettoyage de la surface latérale du trou.

Stellen Sie die Bohrlöcherung unter Kontrolle der Rechtwinkligkeit her. Blasen Sie die Bohrlöcherung mit einer entsprechenden Pumpe (oder Druckluft) durch, nehmen Sie eine Reinigung der seitlichen Oberflächen der Bohrlöcherung mit einer Bürste von Metall vor, blasen Sie die Bohrlöcherung erneut durch, bis kein Pulver und / oder andere Materialrückstände mehr austreten. Insbesondere ist die Benutzung der Metallbürste für die Reinigung der seitlichen Oberfläche der Bohrlöcherung notwendig.

## 02 APERTURA | OPENING | OUVERTURE | ÖFFNUNG

BCR 300  
BCR 165



CARTUCCIA A SACCHETTO  
FOIL CARTRIDGE (CIC)



Togliere il tappo a pressione, avvitare il miscelatore e inserire la cartuccia nella pompa usando protezioni per mani e viso. Nei formati 300 ml e 165 ml svitare il tappo, estrarre la clip metallica secondo le seguenti operazioni: 1) Inserire il miscelatore nell'asola dell'estrattore in plastica. 2) Tirare l'estrattore per sfilare la clip metallica di chiusura del sacchetto. Dopodiché avvitare il miscelatore, inserire la cartuccia nella pompa usando protezioni per mani e viso.

Remove the pressure cup, screw on the mixer and insert the cartridge in the gun. Use protections for hands and face. With the size 300 ml and 165 ml, unscrew the front cup, pull-out the steel closing clip according to the following operations: 1) Insert the mixer in the eye of the plastic extractor. 2) Pull the extractor to unhook the steel closing clip of the foil. After that, screw on the mixer and insert the cartridge in the gun. Use protections for hands and face.

Retirer le bouchon de pression, visser le mélangeur et insérer la cartouche dans la pompe en utilisant les protections pour les mains et le visage. Pour les formats 300 ml et 165 ml, dévisser le bouchon, extraire le clip métallique selon les opérations suivantes: 1) Insérer le mélangeur dans la fente de l'extracteur en plastique. 2) Tirer l'extracteur pour défaire le clip métallique de fermeture du sachet. Après cela, visser le mélangeur, insérer la cartouche dans la pompe en utilisant les protections pour les mains et le visage.

Entfernen Sie die Druckkappe, schrauben Sie den Mischer an und bringen Sie den Einsatz in der Pumpe unter Verwendung von Schutzmitteln für Hände und Gesicht an. Lösen Sie bei den Formaten zu 300 ml und 165 ml den Verschluss und ziehen Sie die Metallklemme entsprechend folgender Vorgehensweise heraus: 1) Fügen Sie den Mischer in das Langloch der Ausziehvorrichtung aus Kunststoff ein. 2) Ziehen Sie die Ausziehvorrichtung heraus, um die Metallklemme zum Verschließen des Beutels zu entfernen. Schrauben Sie dann den Mischer fest und fügen Sie den Einsatz in die Pumpe unter Verwendung von Schutzmitteln für Hände und Gesicht ein.

BCR 900 / BCR 825 / BCR 585 / BCR 470 / BCR 400 / BCR 385 / BCR 345 / BCR 265

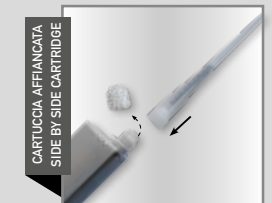
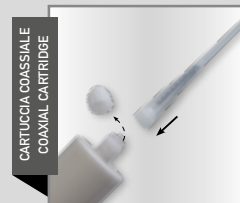

**NOTA.** Dati tecnici, di installazione e di carico possono essere oggetto di revisione. Per una versione aggiornata consultare le schede tecniche sul sito [www.bossong.com](http://www.bossong.com) o contattare il nostro Ufficio Tecnico.

**WARNING.** Installation and loads technical data can be modified by us. For update technical data sheet see [www.bossong.com](http://www.bossong.com) or be in contact with our Technical Office.

**NOTE.** Données techniques, d'installation et de charge peuvent être objet de révision. Pour une version mise à jour, consulter les fiches techniques dans le site internet [www.bossong.com](http://www.bossong.com) ou contacter notre Bureau Technique.

**ANMERKUNG.** Technische Daten, Installationsangaben und Lastdaten können modifiziert werden. Für die aktualisierte Version sind die technischen Blätter auf der Webseite [www.bossong.com](http://www.bossong.com) nachzuschauen, oder unser Technisches Büro soll konsultiert werden.

# SCHEDA TECNICA TECHNICAL DATA SHEET FICHE TECHNIQUE TECHNISCHES DATENBLATT



## 03 PREPARAZIONE DELLA CARTUCCIA | CARTRIDGE PREPARATION PREPARATION DE LA CARTOUCHE | KARTUSCHE VORBEREITUNG



Utilizzare dispenser appropriato  
Use the correct dispenser  
Utiliser un distributeur approprié  
Verwenden Sie einen geeigneten Spender

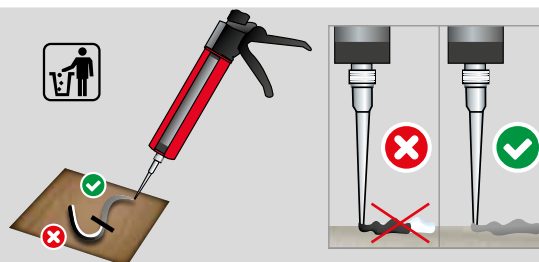

Estrudere una prima parte del prodotto assicurandosi che: 1) Attraverso il mixer (trasparente) il flusso di prodotto sia composto dalla parte A (colore bianco) e dalla parte B (colore nero). 2) I due componenti si siano completamente miscelati. La completa miscelazione è raggiunta quando dal miscelatore il prodotto, ottenuto dall'unione dei due componenti, fuoriesce con colore uniforme. Solo allora la cartuccia è pronta per l'uso.

Before starting to use the cartridge, eject a first part of the product, being sure that: 1) Through the mixer (transparent) see that the flux of product is compound of the part A (white colour) end of part B (black colour). 2) The two components are completely mixed. The complete mixing is reached only after that the product, obtained by mixing the two component, comes out from the mixer with an uniform colour. Now the cartridge is ready to be used.

Extruder une première partie du produit en s'assurant que: 1) Travers le mélangeur (transparent) le flux de produit est composé par les composants A (blanc) et B (noir). 2) Les deux composants soient complètement mélangés. Le mélange complet est atteint quand le produit obtenu par l'union des deux composants sort du mélangeur avec une couleur uniforme. Alors seulement, la cartouche est prête à l'emploi.

Ziehen Sie einen ersten Teil des Produktes heraus und prüfen Sie dass: 1) Durch den Mischer (transparent) ist der Fluss des Produktes aus Teil A (weiße Farbe) und Teil B (schwarze Farbe) zusammengesetzt. 2) Die zwei Teilen werden völlig gemischt. Die komplette Mischung erfolgt als vom Mischer das Produkt, sich ergebend von den zwei Teilen, mit gleichmäßiger Farbe entweicht. Da ist die Kartusche fertig für die Anwendung.

## 04 INIEZIONE | INJECTION | INJECTION | INJEKTION

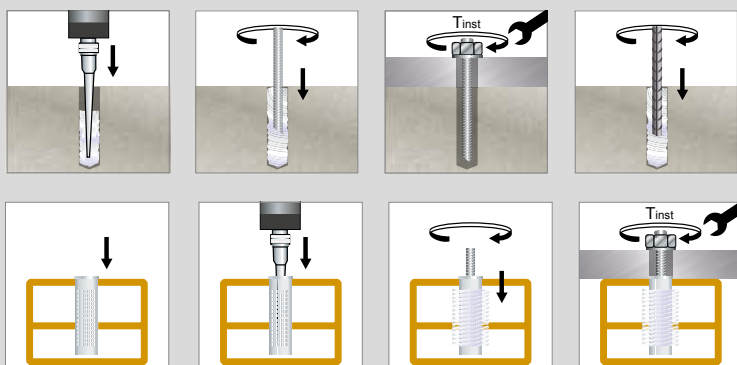

1) Estrudere la resina nel foro fino a riempirlo per 2/3. In caso di materiale forato inserire la gabbietta di plastica e poi estrarre nella gabbietta. 2) Prima di inserire la barra verificare che la superficie della stessa sia asciutta, priva di olio ed altri agenti contaminanti. Inserire la barra con un movimento rotatorio per la fuoriuscita delle bolle d'aria. 3) Per l'installazione della barra e la successiva messa in carico rispettare i relativi tempi di posa specificati sia nella scheda tecnica che sull'etichetta del prodotto. 4) Prima della messa in carico verificare l'indurimento del prodotto. 5) La cartuccia può essere riutilizzata successivamente sostituendo il mixer con uno nuovo. Raccomandiamo di pulire gli ugelli di uscita da eventuali residui di prodotto indurito prima di montare il nuovo mixer. Ricordarsi sempre di estrarre una parte del prodotto vedi punto 3.

1) Inject resin into the hole up to fill it 2/3rds. In hollow bricks use the plastic sleeve and inject the resin inside. 2) Before insert the rod, verify that the element is dry and free oil and other contaminants. Insert threaded stud turning back and forth to avoid presence of air in the fitted hole. 3) For the installation and the following anchor load phase, respect the open time and curing time detailed in the technical data sheet and in the label of the product. 4) Before to load the anchor, check the hardened of the product. 5) The cartridge can be used again screwing the cup and replacing the mixer. We recommend cleaning the product outlet nozzles from any residues of hardened product before assembling the new mixer. Remember to eject a first part of the product, see point 3.

1) Extruder la résine dans le trou jusqu'à le remplir aux 2/3. En cas de matériel troué, insérer la forme en plastique et ensuite extruder dans la forme. 2) Avant d'insérer la barre, vérifier que la surface est sèche, sans rest de huile ou d'autres agents contaminants. Insérer la barre avec un mouvement de rotation pour faire sortir les bulles d'air. 3) Pour l'installation de la barre et le suivant chargement de l'ancrage, respecter les temps de prise indiqués sur la fiche technique et sur la cartouche. 4) Avant de charger l'ancrage, vérifier le durcissement du produit. 5) La cartouche peut être réutilisée par la suite en remplaçant le mixer par un nouveau. Nous recommandons de nettoyer les buses de sortie du produit de tout résidu de produit durci avant d'assembler le nouveau mélangeur. Se rappeler de toujours extruder une partie du produit voir point 3.

1) Pressen Sie das Harz in das Bohrloch bis diese zu 2/3 gefüllt ist. Bei Lochmaterialien muss der Siebhülse eingefügt und dann in die Hülse gepresst werden. 2) Vor dem Einstecken des Gewindestabes prüfen dass seine Fläche trocken, ohne Öl und andere verunreinigende Wirkstoffe ist. Fügen Sie den Stab mit einer Drehbewegung ein, um die Luftblasen austreten zu lassen. 3) Warten Sie die Aushärzeit und Verladungszeit ab, die im technischen Datenblatt und auf dem Etikett des Produktes angegeben sind. 4) Vor der Verladung überprüfen dass das Produkt verhärtet ist. 5) Der Einsatz kann später wiederverwendet werden, indem der Mischer durch einen neuen ersetzt wird. Wir empfehlen, vor dem Zusammenbau des neuen Mischers die Produktaustrittsdüsen von eventuellen Rückständen des ausgehärteten Produkts zu reinigen. Vergessen Sie nicht, immer einen Teil des Produktes herauszupressen, siehe Punkt 3.



## i CONSUMPTION CALCULATOR



[www.bossong.com/area-tecnica.html](http://www.bossong.com/area-tecnica.html)

[www.bossong.co.uk/technical-area](http://www.bossong.co.uk/technical-area)

[www.bossong.fr/section-technique.html](http://www.bossong.fr/section-technique.html)

[www.bossong-befestigungssysteme.de/technische-abteilung.html](http://www.bossong-befestigungssysteme.de/technische-abteilung.html)